

CAD FILE:

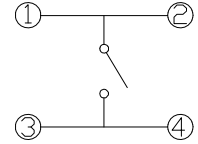

SCHEMATIC

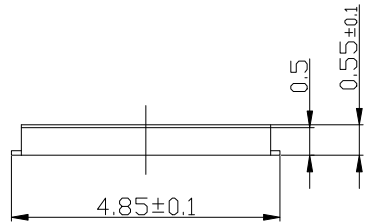
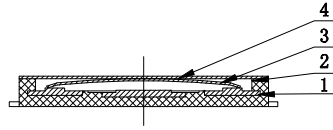
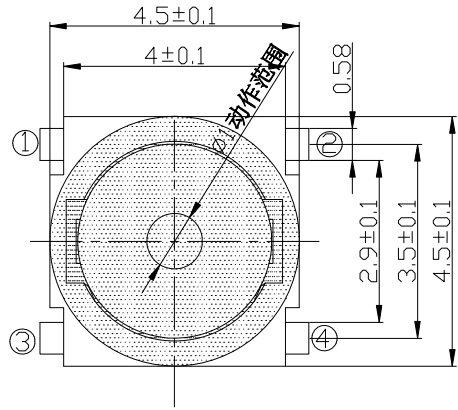
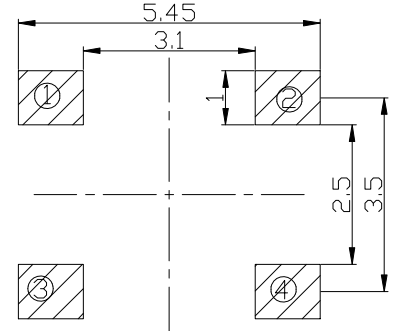

P.C.B LAYOUT

8					TOLERANCE UNLESS SPECIFIED	DONGGUAN DISONG ELECTRONIC CO., LTD.				
7										
6					WITHIN: 1.5±0.1mm OVER: 1.5±0.2mm	ISSUE	DATE	DESCRIPTIONS OF REVISION		APPD.
5										
4	CONTACT	SUS	1	Ag CLAD	TITLE : TACT SWITCH		UNIT : mm	DRWG NO.: TD-016		
3	CASE	NYLON 46/NYLON+F.G/BRASS STRIP	1	BLACK/Ag PLATED						
2	COVER	PET/ZINC PLATE	1	WHITE/Ni PLATED	MODEL:TD-016		SCALE: 6:1	DWN.	ZHOUYU	2005-3-27
1	KNOB	NYLON+F.G	1	BLACK				CHK'D	FANGYING	2005-3-27
NO.	PARTS	MATERIALS	Q'TY	FINISH	ALL MATERIALS MUST BE COMPLIANT TO ROHS			APPD.	KANGXINAN	2005-3-27