

**RoHS
Compliant**

SYMBOL	REVISION	APPROVAL	DATE

SPECIFICATIONS

- ELECTRICAL CHARACTERISTICS:
 - 1-1.RATING: DC 20V 3A MAX
 - 1-2.CONTACT RESISTANCE: 20m Ω MAX(INITIAL)
 - 1-3.DIELECTRIC WITHSTANDING VOLTAGE: 500V AC FOR ONE MINUTE
 - 1-4.INSULATION RESISTANCE: 100M Ω MIN, MEASURED BY 500V DC
- LIFE TEST:MECHANICAL LIFE TEST 10,000 CYCLES MIN
- TEMPERATURE RISE : 30°C MAX

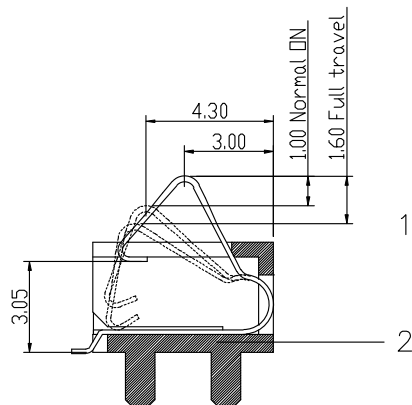
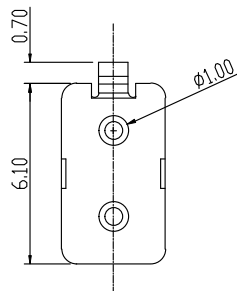
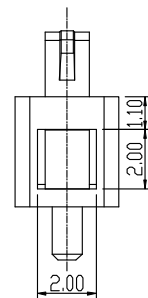
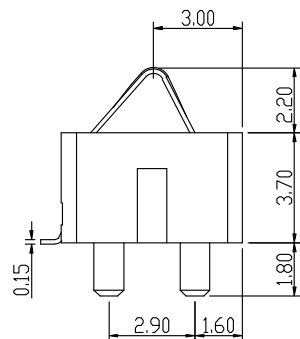
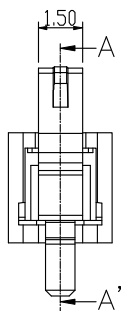

VIEW A-A'

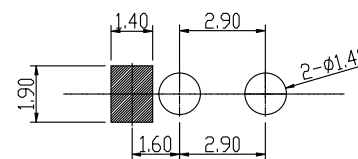

P.C.B LAYOUT



CIRCUIT

2	HOUSING	LCP	1	GRAY
1	CONTACT TERMINAL	BeCu	1	Au PLATED
NO.	PARTS	MATERIAL	QTY.	FINISHING

DISONG ELECTRONIC CO., LTD.

COPYRIGHT RESERVED, PLEASE DO NOT COPY.

PART NAME		CONNECTOR		DRAWING	Z.L.Liang	DWG.No.	
PART NO.		BC-1-102		CHECK	G.C.Chen	REV.	A1
UNIT :	TOLERANCE	UP TO 5	±0.2	ANGLE	APPROVAL	DATE	31-03-2021
	OTHERWISE	ABOVE 5 TO 30	±0.3			SCALE	1:1
mm		ABOVE 30	±0.5	0°±3'			